

- A. General
- B. Fault diagnosis with impulse counter
 - a) Connecting diagram, impulse counter
 - b) Connecting diagram, socket box
- C. Test program with socket box and multimeter
 - a) Test on leads at impulse display 3
 - b) Test on leads at impulse display 4
 - c) Test on electrical function, ETR
 - d) Test when no impulse number is displayed
- D. Circuit diagrams
- E. Component layout
- F. Plug connections layout

A. General

A diagnostic program is incorporated in the control unit (N2/2), which checks both the control unit itself and the airbag system components.

If a fault is identified:

- Control lamp (A1e15) does not light up with the ignition key in position 1.
- It does not go out after 4 s.
- It lights up when the vehicle is being driven.

When the fault has been rectified, the control lamp goes out again but the fault is memorized. The stored fault can be checked as a flashing pulse via the control lamp (A1e15) or digitally via an impulse counter. The number of flashing pulses indicates the type of fault identified (see Impulse Display table).

91-710 Test program, airbag and ETR (from 09/87)

Test requirements

- With an impulse output, the test connection/airbag plug connector (X29/9) remains connected.
- Battery voltage (11 – 14 V).

Special tools

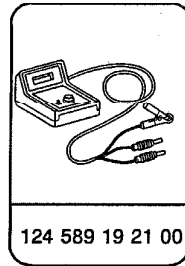
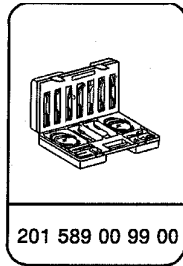
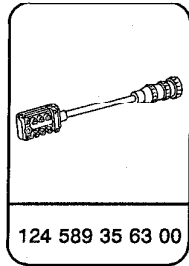
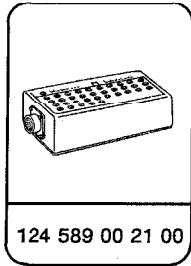

Commercially available tools

Multimeter

e.g. Sun, DMM-5 or
Hermann, Avometer 2003

B. Fault diagnosis with impulse counter

Notes on impulse display

If, in a case of complaint, no fault is indicated by the impulse display, carry out function test, Section C/4.

The number 1 signifies that no fault is present in the electronic system. All other numbers are assigned to a specific, faulty circuit.

Numbers 1-10 appear in the impulse counter display panel.

- If the LED U-Batt appears after connection the impulse counter and power supply to the impulse counter are in order.

Testing

- Connect impulse counter in accordance with connecting diagram.

Note

LED U-Batt must light up in display panel. If not, set multimeter to voltage mode and:

- a) Test socket 1 of test connection X92 against positive battery terminal (11-14V).
 - b) Test socket 6 of test connection X92 against socket 1 (6-12V).
- Operate start button for 2-4 seconds.
 - Read off and record impulse output display.
 - Operate start button again for 2-4 seconds. If no further faults are present in the system, the previously displayed value will reappear.
 - Rectify recorded faults (impulse output) in accordance with fault diagnosis program.
 - Carry out checks on individual components.

Reset fault memory

After a fault has been rectified, the displayed impulse must be cancelled as follows:

- Operate start button and read off rectified fault, then operate start button for at least 6-8 seconds.

Note

Every impulse displayed must be cancelled individually.

- If no display, the stored fault has been cancelled.
- If a number is displayed (>1), there are further faults in the system.

a) Connecting diagram: impulse counter

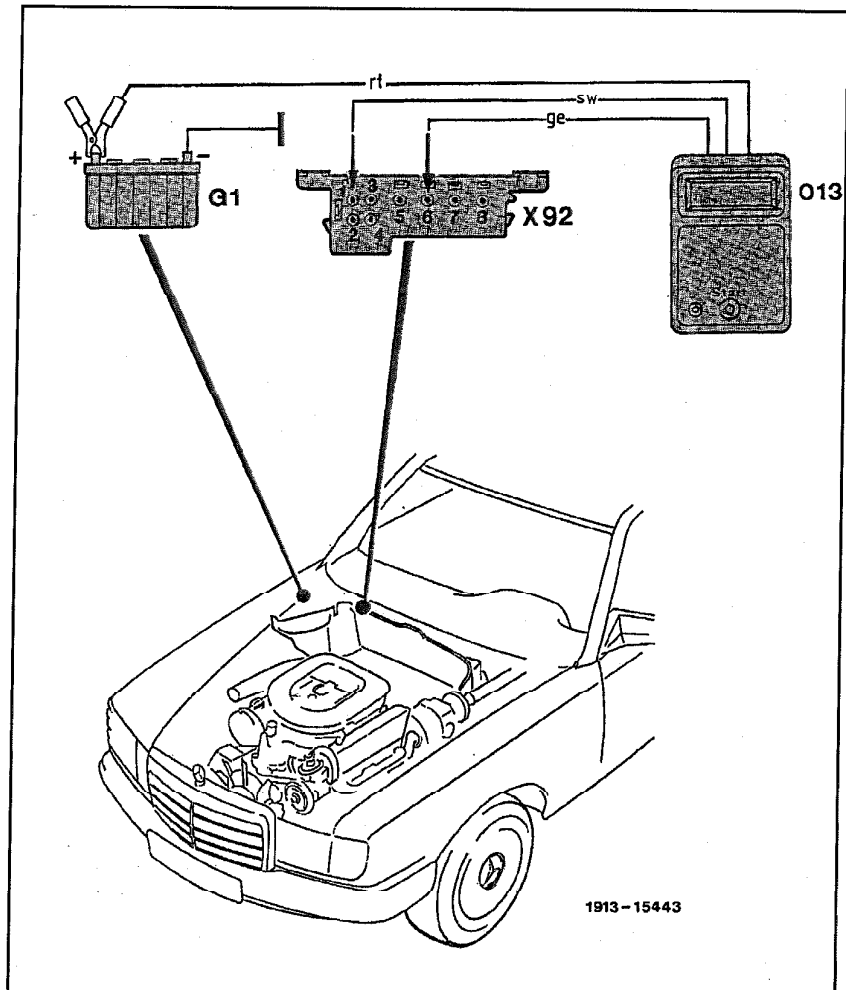

- 013 Impulse counter
- G1 Battery
- X92 Test connection for diagnosis, 8-pole flasher code

1913-15443

91-710 Test program, airbag and ETR (from 09/87)

The impulse number indicates the existence and type of fault, or which components are defective.

Impulse display 10 indicates that the control unit has triggered the airbag unit end-stages. This display cannot be cancelled.

The control unit must be replaced.

Impulse	Fault display
1	No fault stored in memory
2	Control unit
3	Ignition circuit, driver's airbag
4	Ignition circuit, front passenger's airbag
5	Driver's belt lock
6	Front passenger's belt lock
7	Resistor, front passenger's seat, airbag
8	Low voltage
9	Control lamp
10	Control unit

b) Connecting diagram, socket box

Note

Before disconnecting the test connection at the 10-pin airbag plug connector, the negative battery terminal must be disconnected and insulated.

Connecting diagram, socket box

- 01 Test connection, 10-pin airbag plug connector
- 02 Test lead
- 03 Multimeter
- 04 Socket box

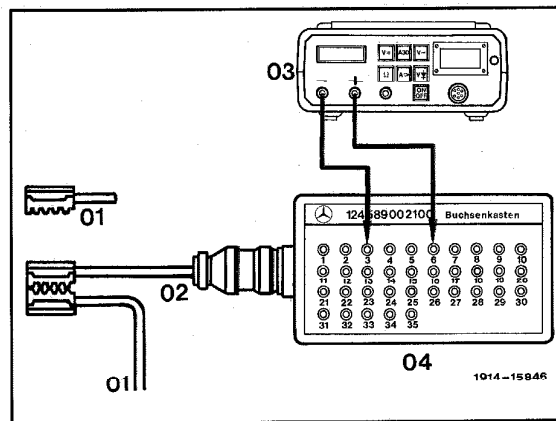

1914-15846

C. Test program with socket box and multimeter

Test instrument symbols:



Socket box



Battery





Multimeter

Display	Test stage/ test scope	Test instrument/ test connection	Actuation/ prerequisite	Nominal value	Possible cause/ remedy
1	1	-	-	-	No fault in memory
2	Control unit		Ignition: ON Cancel impulse display 2 Impulse display 2 cannot be cancelled. Ignition: OFF Disconnect and insulate negative battery terminal. Disconnect test connection (X29/9).	Impulse display 2 cancelled	- Replace control unit
3 1)	Driver's airbag slip ring, leads to (X29/9)		Ignition: OFF Disconnect and insulate negative battery terminal Disconnect test connection (X29/9) and connect test lead. Turn steering wheel to full lock right and left.	2 - 5 Ω $\infty \Omega$	Airbag unit, 4-way carbon brushes, slip ring, leads (interruption, short circuit) Short to ground

1) If test for impulse display 3 is in order but display cannot be cancelled, test leads in accordance with section C/1.

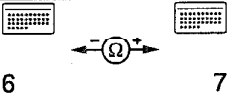
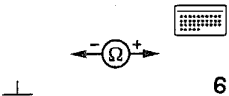
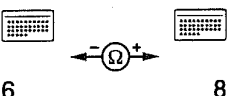
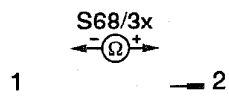
91-710 Test program, airbag and ETR (from 09/87)

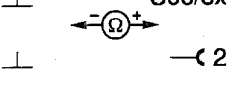
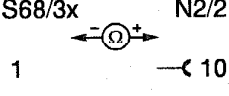
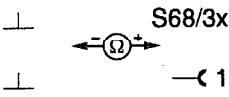
Display	Test stage/ test scope	Test Instrument/ test connection	Actuation/ prerequisite	Nominal value	Possible cause/ remedy
4 1)	Front passenger's airbag	 6 7	Ignition: OFF Disconnect and insulate negative battery terminal. Disconnect test connection (X29/9) and connect test lead.	2 - 5 Ω	Front passenger's airbag leads
		 ⊥ 6		∞ Ω	Short to ground
		 6 8		2 - 5 Ω	Front passenger's airbag leads
5	Driver's belt buckle	 1 2	Disconnect plug connector (S68/3x) Buckle not fastened. Buckle fastened.	400 ± 10 Ω	Belt buckle
		 ⊥ 2		100 ± 10 Ω	
	Leads	 ⊥ S68/3x ⊥ 2	Disconnect plug connector (S68/3x)	< 1 Ω	Lead interrupted
	Leads	 S68/3x N2/2 1 10	Ignition: OFF Disconnect and insulate negative battery terminal. Disconnect test connection (X29/9). Disconnect plug connector from control unit.	< 1 Ω	Lead interrupted
Leads	 ⊥ S68/3x ⊥ 1		∞ Ω	Short to ground	

1) If test for impulse display 4 is in order but display cannot be cancelled, test leads in accordance with section C/2.

91-710 Test program, airbag and ETR (from 09/87)

Display	Test stage/ test scope	Test instrument/ test connection	Actuation/ prerequisite	Nominal value	Possible cause/ remedy
6	Front passenger's belt buckle		Disconnect plug connector (S68/4x)		Belt buckle
			Buckle not fastened.	$400 \pm 10 \Omega$	
			Buckle fastened.	$100 \pm 10 \Omega$	
	Leads		Disconnect plug connector (S68/4x)	$< 1 \Omega$	Lead interrupted
6	Leads		Ignition: OFF Disconnect and insulate negative battery terminal. Disconnect test connection (X29/9). Disconnect plug connector from control unit	$< 1 \Omega$	Lead interrupted
	Leads			$\infty \Omega$	Short to ground
7	Resistor, front passenger's seat, airbag, Model 126, type 1		Disconnect plug connector R32x	$100 \Omega \pm 10 \Omega$	Resistor

91-710 Test program, airbag and ETR (from 09/87)







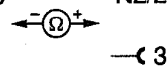
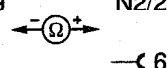
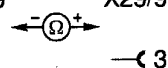

Display	Test stage/ test scope	Test instrument/ test connection	Actuation/ prerequisite	Nominal value	Possible cause/ remedy
	Leads, Model 126, type 1	<p>R32x —C 3</p>	Ignition: OFF Disconnect and insulate negative battery terminal.	< 1 Ω	Lead interrupted
		<p>R32x —C 1</p>	Disconnect test connection (X29/9)	∞ Ω	Short to ground
		<p>R32x —C 1 —C 15</p>	Disconnect plug connector from control unit.	< 1 Ω	Lead interrupted
	Resistor, front passenger's seat, airbag Model 126 ¹⁾ type 2	<p>N2/2 —C 12 —C 15</p>	Ignition: OFF Disconnect and insulate negative battery terminal. Disconnect test connection (X29/9). Disconnect plug connector from control unit.	100 Ω ± 10	Interruption
8	Power supply	<p>(X29/9) —C 2</p>	Ignition: OFF Disconnect and insulate negative battery terminal. Disconnect test connection (X29/9). Ignition: ON	11 - 14 V	Battery, alternator Ignition starter switch X28/2 Check lead from X28/2 to N2/2 as per circuit diagram. Note To check the lead: Ignition: OFF Disconnect and insulate negative battery terminal. Disconnect test connection (X29/9). Disconnect plug connector from control unit.

1) On type 2, the lead to the front passenger's seat is omitted.

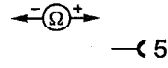

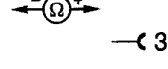
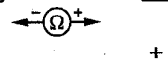

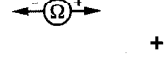

91-710 Test program, airbag and ETR (from 09/87)

Display	Test stage/ test scope	Test Instrument/ test connection	Actuation/ prerequisite	Nominal value	Possible cause/ remedy
9	Control lamp Power supply	A1e15 pink ← (V) → pink/yellow black/red	Ignition: ON Ignition: ON	Control lamp lights up 11 – 14 V	Control lamp Control lamp Check leads from A1e15 to N2/2 and X28/2 or to fusebox for interruption, short circuit and shorting to positive as per circuit diagram. Note To check the lead: Ignition: OFF Disconnect and insulate negative battery terminal. Disconnect test connection (X29/9). Disconnect plug connector from control unit.
10	Control module	-	Ignition: OFF Disconnect and insulate negative battery terminal. Disconnect test connection (X29/9)	-	Replace control module.

a) Check on leads following impulse display 3

Display	Test stage/ test scope	Test instrument/ test connection	Actuation/ prerequisite	Nominal value	Possible cause/ remedy
3	Check leads X29/9 - N2/2 for interruption	X29/9  N2/2 —C 5 —C 3	Ignition: OFF Disconnect and insulate negative battery terminal	< 1 Ω	Interruption
		X29/9  N2/2 —C 3 —C 6	Disconnect test connection (X29/9). Disconnect plug connector from control unit.	< 1 Ω	Interruption
	Check leads X29/9 - N2/2 for short circuit	X29/9  X29/9 —C 5 —C 3		∞ Ω	Short circuit
	Check leads X29/9 -N2/2 shorting for to ground	  X29/9 —C 5		∞ Ω	Short to ground
		  X29/9 —C 3		∞ Ω	Short to ground
	Check leads X29/9 for shorting to positive	X29/9   —C 5 +		∞ Ω	Short to positive
		X29/9   —C 3 +		∞ Ω	Short to positive

b) Check on leads following impulse display 4

Display	Test stage/ test scope	Test instrument/ test connection	Actuation/ prerequisite	Nominal value	Possible cause/ remedy
4	Leads X29/9 - X29/9	X29/9  X29/9 -C 5 -C 6	Ignition: OFF Disconnect and insulate negative battery terminal. Disconnect test connection (X29/9). Disconnect plug connector from control unit.	< 1 Ω	Interruption
	Check X29/9 - N2/2 for interruption	X29/9  N2/2 -C 5 -C 2 -C 8 -C 13 -C 7 -C 14		< 1 Ω	Interruption
	Check X29/9 - N2/2 for short circuit	X29/9  X29/9 -C 5 -C 7 -C 5 -C 8 -C 7 -C 8		∞ Ω	Short circuit
	Check leads ⊥ - X29/9 for shorting to ground	⊥  X29/9 ⊥ -C 5 ⊥ -C 7 ⊥ -C 8		∞ Ω	Short to ground
	Check X29/9 leads for shorting to positive	X29/9   -C 5 + -C 7 + -C 8 +		∞ Ω	Short to positive

c) ETRs, electrical function check

The ETRs are not checked via the airbag control unit. They must be checked after working on the airbag restraint system as follows:

Test instrument symbols:



Socket box



Multimeter

Test program with socket box

Display	Test stage/ test scope	Test instrument/ test connection	Actuation/ prerequisite	Nominal value	Possible cause/ remedy
Not covered by impulse display	Driver's belt tensioner		Ignition: OFF Disconnect and insulate negative battery terminal	2 - 5 Ω	ETR leads
			Disconnect test connection (X29/9) and connect test lead.	∞ Ω	Short to ground
	Front passenger's ETR			2 - 5 Ω	ETR leads

d) Checks to be carried out when no impulse display appears

Test requirements

- Test connection/airbag plug connector (X29/9) connected.
- Battery voltage 11 – 14 V
- Impulse counter connected in accordance with connection diagram.
(—C black lead 1, —C yellow lead 6).
- Ignition on.
- Impulse counter start button applied for 2-4 seconds.

Special tools

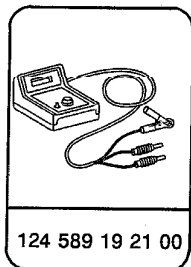
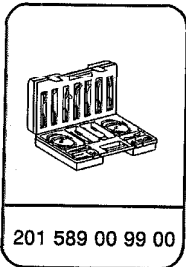

Commercially available test instrument

Multimeter

e.g. Sun, DMM-5 or
Avometer 2003

Tests

- 1 Check whether jack 6 in the diagnostic 8-pole test connection (X92) is correctly retained.
- 2 With multimeter and set of connecting leads, check leads as per test program.

Test program

Test instrument symbol:



Multimeter

Display	Test stage/ test scope	Test instrument/ test connection	Actuation/ prerequisite	Nominal value	Possible cause/ remedy
	Check lead ┌ - X92 for interrup-tion	┌ X92 └ ← Ω → ┌ - C 1	Ignition: OFF	< 1 Ω	Lead interrupted
	Check lead X92 - N2/2 for interrup-tion	X92 └ ← Ω → └ - C 6 - C 3	Ignition: OFF Disconnect and insulate negative battery terminal. Disconnect test connection X29/9. Disconnect plug connec- tion from control unit (N2/2).	< 1 Ω	Lead interrupted. Model 126, plug connector X28/7 not making contact.
	Check lead ┌ - X92 for shorting to ground	┌ X92 └ ← Ω → ┌ - C 6		∞ Ω	Short to ground

Remedy:

If all the values specified in the table are met, the control unit must be replaced.

When the test connection - 10-pole airbag plug connector is disconnected, all the pins are short circuited. When the connectors for the ETR squibs (R12/1, R12/2) and airbag squib (R12/3) are disconnected, the squibs are short circuited.

91-710 Test program, airbag and ETR (from 09/87)

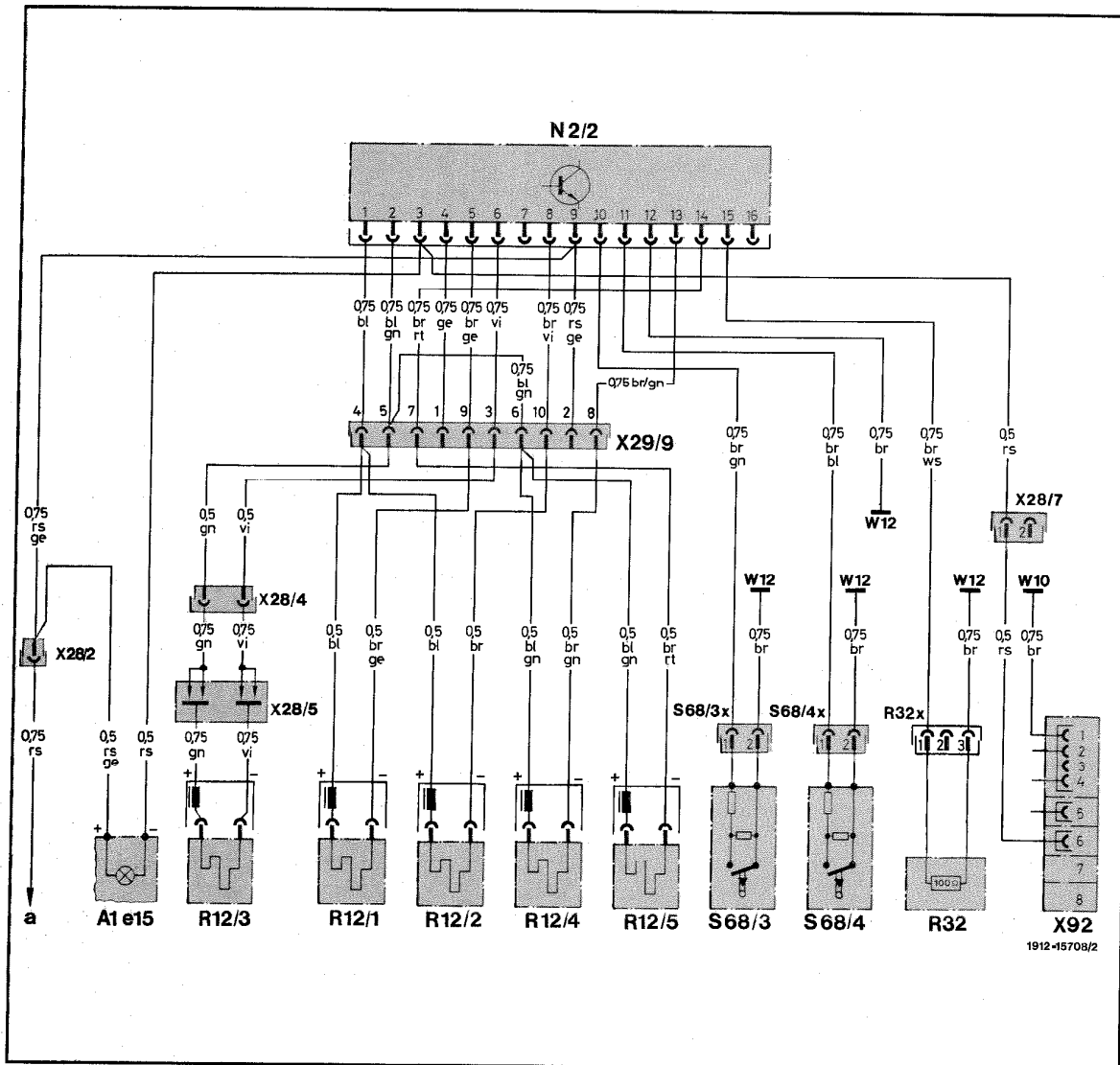

1912-15708/2

Electrical circuit diagram, Model 126, driver's and front passenger's airbag with ETRs.

type 1

A1e15	SRS MIL	S68/4	Right front seat belt buckle switch (AB/ETR)
N2/2	SRS control module	S68/4x1	Right front seat belt buckle switch connector (AB/ETR)
R12/1	Left front ETR squib	W10	Ground (battery)
R12/2	Right front ETR squib	W12	Ground (center console)
R12/3	Driver AB squib	X28/2	Plug connector, power supply, airbag with ETR
R12/4	Front passenger AB squib 1	X28/4	Driver AB squib connector (2-pole)
R12/5	Front passenger AB squib 2	X28/5	AB squib slip ring (2-pole)
R32	Front passenger seat AB resistor	X28/7	AB test connector
R32x1	Front passenger seat AB resistor connector	X29/9	Test connection, plug connector, airbag, 10-pole
S68/3	Left front seat belt buckle switch (AB/ETR)	X92	Test connection for diagnosis, 8-pole (flasher code)
S68/3x1	Left front seat belt buckle switch connector (AB/ETR)	a	Fusebox, terminal 15R, unfused side

Note

When the test connection - 10-pole airbag plug connector (X29/9) is disconnected, 8 pins are short circuited. When the connectors for the ETR squibs (R12/1, R12/2) and airbag pellets (R12/3, R12/4, R12/5) are disconnected, the squibs are short circuited.

91-710 Test program, airbag and ETR (from 09/87)

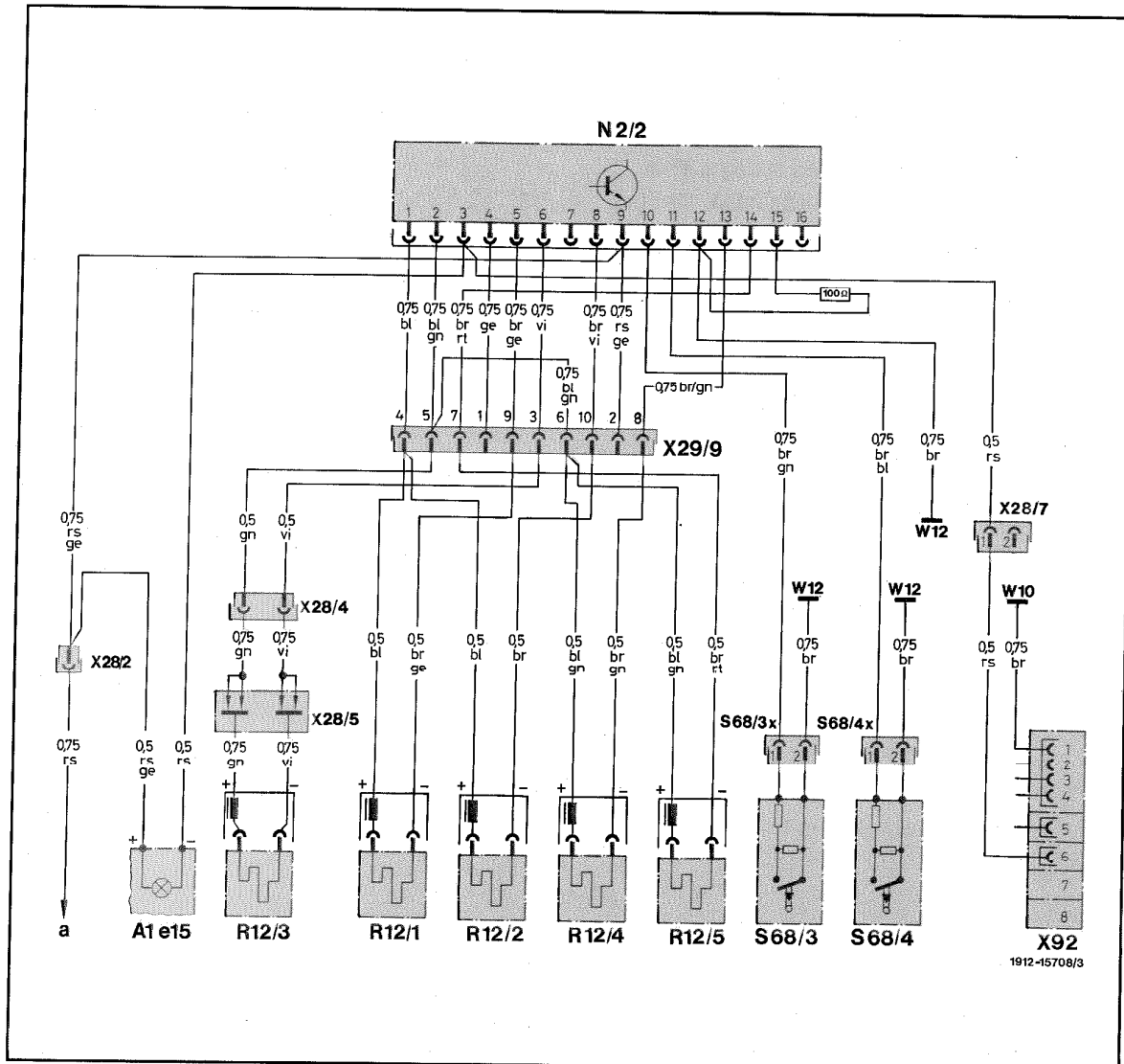

1912-15708/3

Electrical circuit diagram, Model 126, driver's and front passenger's airbag with ETRs, type 2

A1e15	SRS MIL	W10	Ground (battery)
N2/2	SRS control module	W12	Ground (center console)
R12/1	Left front ETR squib	X28/2	Plug connector, power supply, airbag with ETR
R12/2	Right front ETR squib	X28/4	Driver AB squib connector (2-pole)
R12/3	Driver AB squib	X28/5	AB squib slip ring (2-pole)
R12/4	Front passenger AB squib 1	X28/7	AB test connector
R12/5	Front passenger AB squib 2	X29/9	Test connection, plug connector, airbag, 10-pole
S68/3	Left front seat belt buckle switch (AB/ETR)	X92	Test connection for diagnosis, 8-pole (flasher oodo)
S68/3x1	Left front seat belt buckle switch connector (AB/ETR)	a	Fusebox, terminal 15 R, unfused side
S68/4	Right front seat belt buckle switch (AB/ETR)		
S68/4x1	Right front seat belt buckle switch connector (AB/ETR)		

Note

When the test connection - 10-pole airbag plug connector (X29/9) is disconnected, 8 pins are short circuited. When the connectors for the ETR squibs (R12/1, R12/2) and airbag squibs (R12/3, R12/4, R12/5) are disconnected, the squibs are short circuited.

E. Component layout

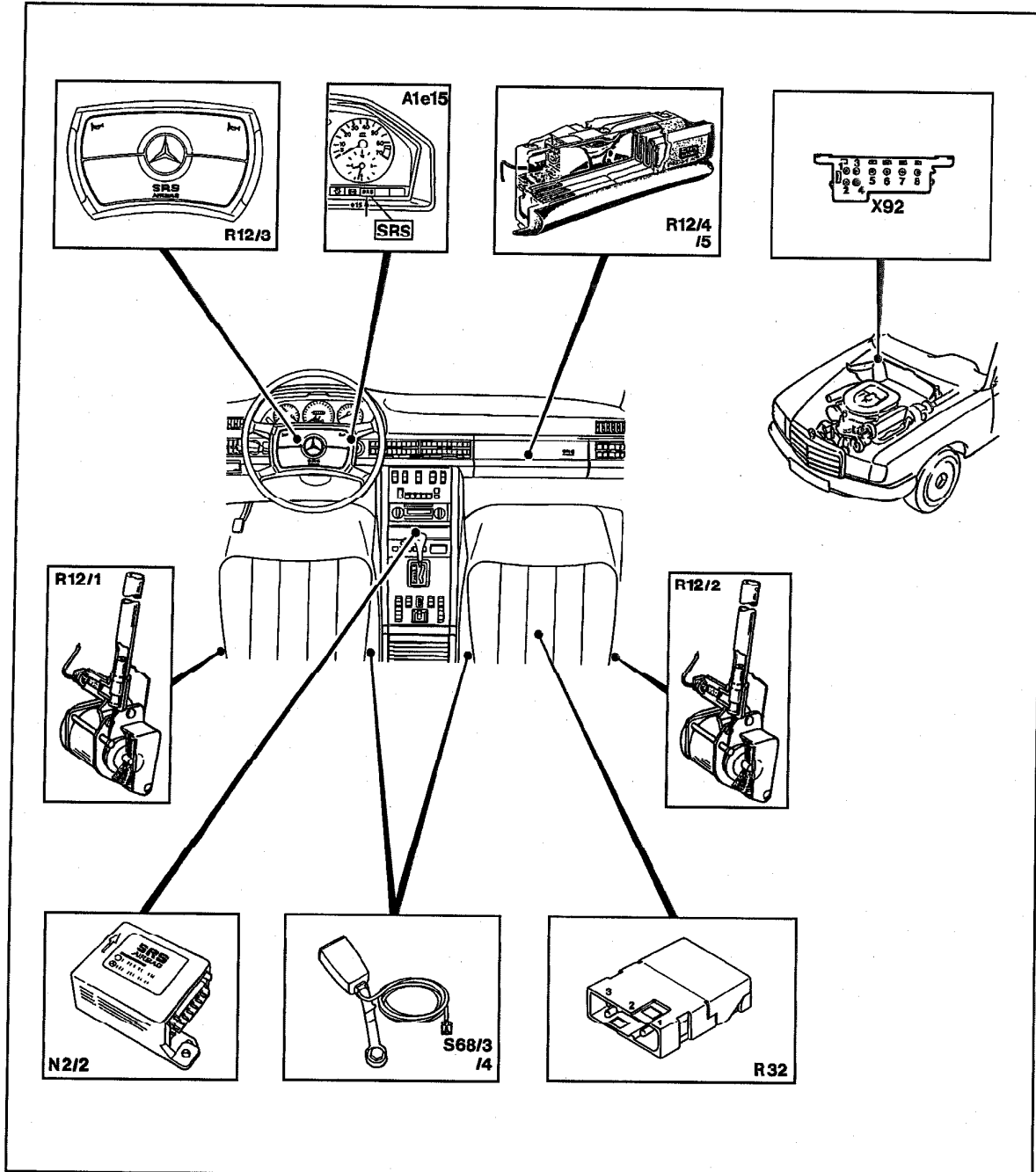

1012-16500

- A1e15 SRS MIL
- N2/2 SRS control module
- R12/1 Left front ETR squib
- R12/2 Right front ETR squib
- R12/3 Driver AB squib

- R32 Front passenger seat AB resistor
- S68/3 Left front seat belt buckle switch (AB/ETR)
- S68/4 Right front seat belt buckle switch (AB/ETR)
- X29/9 Test connection/plug connector, airbag, 10-pole
- X92 Diagnostic test connection diagnosis, 8-pole

F. Plug connections layout

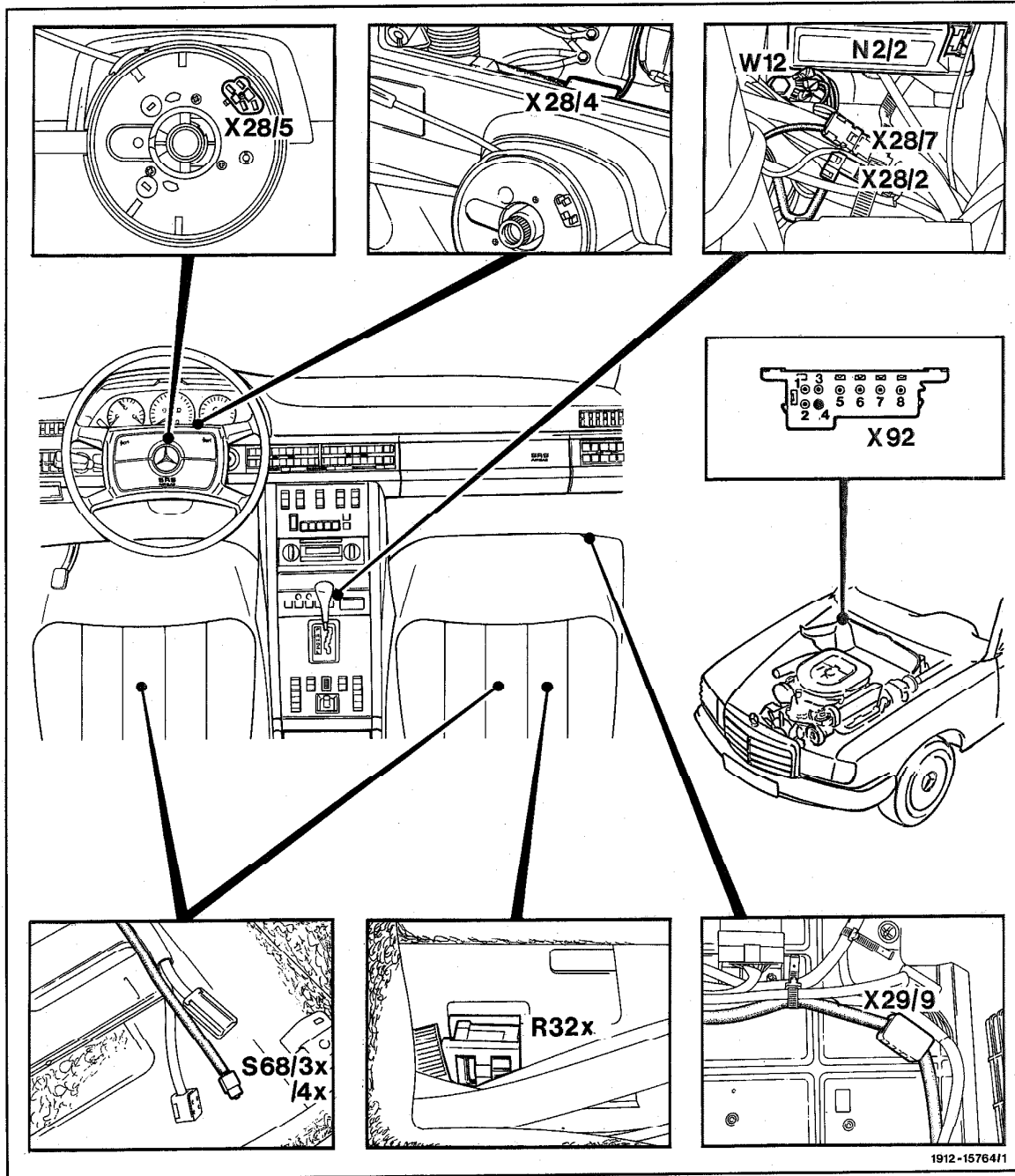

1912-15764/1

1912-15764/1

- | | | | |
|---------|--|-------|--|
| N2/2 | SRS control module | X28/4 | Driver AB squib connector (2-pole) |
| R32x1 | Front passenger seat AB resistor connector | X28/5 | AB squib slip ring (2-pole) |
| S68/3x1 | Left front seat belt buckle switch connector (AB/ETR) | X28/7 | AB test connector |
| S68/4x1 | Right front seat belt buckle switch connector (AB/ETR) | X29/9 | Test connection, plug connector, airbag, 10-pole |
| W12 | Ground (center console) | X92 | Test connection for diagnosis, 8-pole (flasher code) |
| X28/2 | Connector, power supply, airbag with ETR | | |